



REFRIGERATION

SERVING THE FOOD INDUSTRY SINCE 1951

78-INCH 3-DOOR SWING GLASS REFRIGERATOR

Item: 50052 | 51052 Model: RE-CN-0052-HC | RE-CN-0052-HC-BK



50052



51052

*THE PERFECT SOLUTION
TO EXHIBIT COLD MERCHANDISE*

Omcan's 78-inch 3-door swing glass refrigerator is perfect for your products, with the outside material made from painted steel. Its crystal clear, self closing door is perfect to see the products inside. It also features automatic defrosting and high density polyurethane insulation.



WARRANTY

2 YEARS PARTS & LABOR
5 YEARS ONLY ON COMPRESSOR

NEMA
5 - 20R
125 VAC / 20 AMP
RECEPTACLE



Authorized Dealer

REFRIGERATION

78-INCH 3-DOOR SWING GLASS REFRIGERATOR 50052



TECHNICAL SPECIFICATION

ITEM NUMBER	50052
MODEL	RE-CN-0052-HC
DESCRIPTION	3-Door Swing Glass Refrigerator
TEMPERATURE RANGE	0.5°C - 5°C / 33°F - 41°F
MAX AMBIENT TEMP RATING	90°F
POWER	3/4 HP
PHASE	1
ELECTRICAL	110 V / 60 Hz
AMPS	10.7
REFRIGERANT	R290
COOLING SYSTEM	Ventilated
NUMBER OF DOORS	3
NUMBER OF SHELVES	12
SHELF CAPACITY	90 lbs. / 41 kg.
EXTERIOR DIMENSIONS (WDH)	78.27" x 29.9" x 84.64" 1988 x 759 x 2150 mm
INTERIOR DIMENSIONS (WDH)	73.7" x 25.6" x 55.7" 1872 x 650 x 1415 mm
PACKAGING DIMENSIONS	80" x 33" x 87" 2032 x 838.2 x 2209.8 mm
NET VOLUME	53 cu. ft.
NET WEIGHT	615 lbs. / 279 kg.
GROSS WEIGHT	681 lbs. / 309 kg.



Features:

- Outside material: Painted steel
- Self-closing doors
- Plastic coated steel shelves with shelf tag holder
- Automatic defrosting
- Polyurethane insulation
- Removable door gasket
- Casters included
- Shelf Capacity: 90 lbs. / 41 kg.
- Temperature range: 0.5°C - 5°C / 33°F - 41°F

TECHNICAL DRAWING AND DIMENSIONS

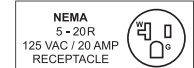
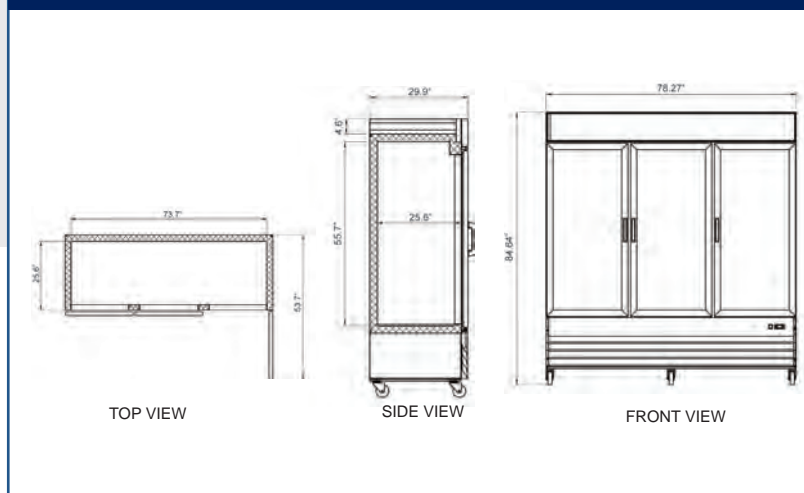

OMCAN INC.

Telephone: 1-800-465-0234
 Fax: (905) 607-0234
 Email: sales@omcan.com
 Website: www.omcan.com



Follow us to keep up to date with the latest news and offers



REFRIGERATION

78-INCH 3-DOOR SWING GLASS REFRIGERATOR 50052



TECHNICAL SPECIFICATION

ITEM NUMBER	51052
MODEL	RE-CN-0052-HC-BK
DESCRIPTION	3-Door Swing Glass Refrigerator
TEMPERATURE RANGE	0.5°C - 5°C / 33°F - 41°F
MAX AMBIENT TEMP RATING	90°F
POWER	3/4 HP
PHASE	1
ELECTRICAL	110 V / 60 Hz
AMPS	10.7
REFRIGERANT	R290
COOLING SYSTEM	Ventilated
NUMBER OF DOORS	3
NUMBER OF SHELVES	12
SHELF CAPACITY	90 lbs. / 41 kg.
EXTERIOR DIMENSIONS (WDH)	78.27" x 29.9" x 84.64" 1988 x 759 x 2150 mm
INTERIOR DIMENSIONS (WDH)	73.7" x 25.6" x 55.7" 1872 x 650 x 1415 mm
PACKAGING DIMENSIONS	80" x 33" x 87" 2032 x 838.2 x 2209.8 mm
NET VOLUME	53 cu. ft.
NET WEIGHT	615 lbs. / 279 kg.
GROSS WEIGHT	681 lbs. / 309 kg.



Features:

- Outside material: Painted steel
- Self-closing doors
- Plastic coated steel shelves with shelf tag holder
- Automatic defrosting
- Polyurethane insulation
- Removable door gasket
- Casters included
- Shelf Capacity: 90 lbs. / 41 kg.
- Temperature range: 0.5°C - 5°C / 33°F - 41°F

TECHNICAL DRAWING AND DIMENSIONS

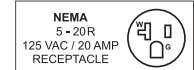
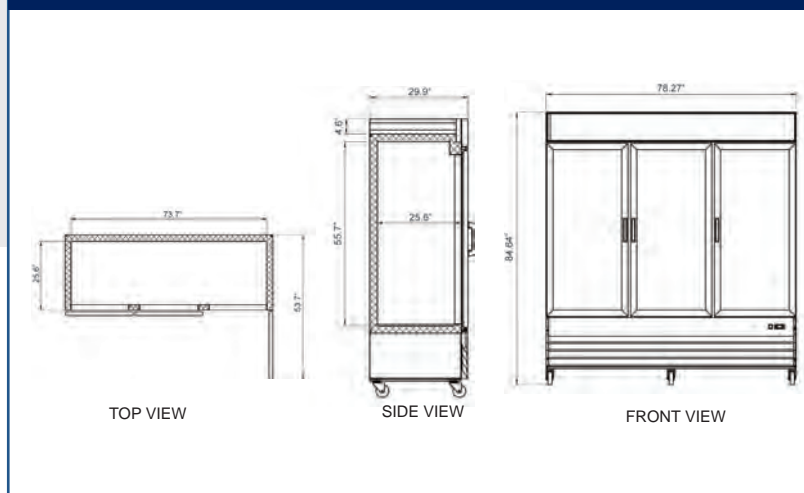

OMCAN INC.

Telephone: 1-800-465-0234
 Fax: (905) 607-0234
 Email: sales@omcan.com
 Website: www.omcan.com



Follow us to keep up to date with the latest news and offers

